

The MS-900 is a modular, eight input SD mobile studio that speeds the workflow of any SD studio or travelling studio.

By using a built in SE-900 switcher, the MS-900 can accept a variety of choices of input boards for DV, SDI, DVI and YUV. In addition S-Video and Composite video. There are two memories for logo displays as well as a CG (Character Generator) overlay channel so you may use a CG (like the CG-100) as a DSK and retain access to the multiple outputs of the SE-900 switcher.

Card options include external synch and also includes a chromakey card that allows cuts between two cameras and two backgrounds. Also Included is an eight channel wired intercom with belt-packs and tally lights.

The shock mounted case of the MS-900 is smaller than you would expect because the 17" monitor for multi-view output folds down into a 1 RU size space for travel. As with all Datavideo products MS-900 works on 12vDC or local power.



Connections

Video

- Inputs: up to 8 inputs with a choice of SDI, DV, DVI, component (Y:U:V), S-Video (Y/C) & Composite
- Outputs: Optional SDI, DV, YUV, S-Video and/or Composite
- Inputs: both balanced XLR and RCA with audio delay for perfect sync with DV or SDI video sources
- Outputs: one balanced XLR +/- 12Vp-p, 1 RCA stereo

Control

- RS-232 or RS-422 control interface

Monitor

- Advanced multi-screen monitor for confident preview of each source with next source/effect preview and program output – with overlay tally indicator

Recorder

- Built-in DN-500 hard disk recorder for video recording and playback

Intercom

- Keeping communication open between the camera crew, the producer, lighting, floor manager, etc. is vital in any live production. ITC-100 is an 8 channel talkback/intercom system that comes supplied complete with 8x camera man belt packs with headset/microphone & tally box indicator

Power Distribution Center

- Integrated Datavideo PD-1 power distribution center provides a simple and secure solution for connecting power in the studio or in the field from a 12V source, such as a generator

Optional

- Converts composite video with audio into a realtime MPEG-4 video stream with the NVS-10 network video server

Features

- Virtual studio with up to four live camera inputs. Requires optional chromakey card
- Built in frame synchronizer and TBC for each channel, no external gen-lock is required for flicker free switching between all 8 inputs – in any format
- Designed to be “live-in-seconds” with easy setup, breakdown and storage at any location
- Anti shock padding protects the MS-900 during transit
- Each input card offers a Composite Video Preview Output, irrespective of the input type
- Include an audio delay function as well as a DV/SDI audio embedder for output
- Each DV and SDI video input has an audio de-embedder which provides dual channel balanced audio output

I/O Cards

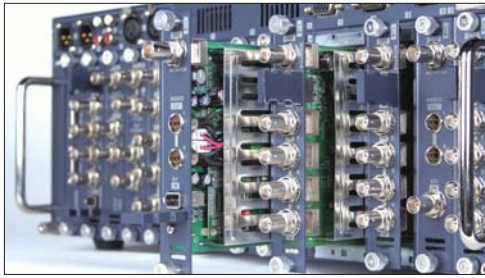

Easy installation of optional I/O cards including SDI, DVI, Down Stream Keyer, Genlock and more.

All inputs are synchronized internally, so no genlock is required, even between consumer camcorders/players and computer equipments.

Rear View



Included Cards



External Control Card

RS-232, RS-422 & GPI control interface board allows easy integration with existing equipment that can be controlled such as tape recorders and players or presentation control panels.



Multi-image Preview Output Card

The multi-image output display allows all inputs, master & next source output to be displayed on a single monitor, with super-imposed tally and source info to assist the producer in a hectic live production environment.



SDI Overlay Card

A down stream keyer (DSK) board that offers both Internal and External keying options. Perfect for integration with character generator hardware/software such as Datavideo CG-100 or CG-350.

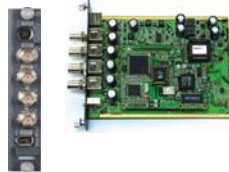

Analog & DV Output Card

Output card for a range of popular video formats – DV (with embedded audio from the audio delay circuit), composite video, S-video (Y/C) and component (Y:U:V).

I/O Cards



SDI Input Card

For users who work with SDI. Also includes audio de-embedding to a balanced pair. Features a useful composite monitor output for easy connection to an external preview monitor



DVI-D & VGA Input Card

Connect a computer and switch between live video and popular computer applications such as presentation and more. Perfect for live events like worship and company presentations. Features a composite monitor output, for easy connection to an external preview monitor.

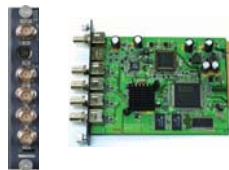

Analog Video Input Card

For users who require input from a range of popular analog video formats including composite video, S-video (Y/C) and component (Y:U:V). Built-in TBC syncs each input, enabling non-genlock gear to be used without glitches. Features a useful Composite Video monitor output, for easy connection to an external preview monitor.

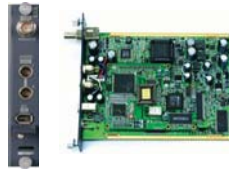

DV Input Card

For users who work with digital video (DV). The DV input board also de-embeds the audio to a pair of balanced outputs.



Four-Channel Chromakey Function Card (Optional)

Create a virtual chromakey video studio with glitch-free switching between up to four video inputs. You can pair 4 fore-grounds (e. g. talent/actor in front of the camera) and backgrounds (like 3D backgrounds). The internal TBC takes care of synchronizing, even non-genlock equipment, like consumer camcorders can be used.

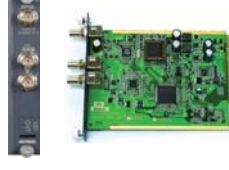

SDI Output Card

For users who work with SDI. The SDI Output board also features a useful composite Video monitor output, for easy connection to an external preview monitor.

Dimensions

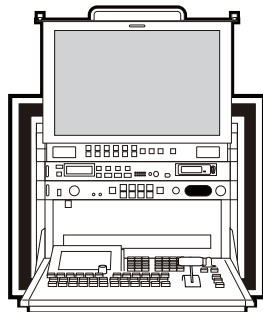

Width: 24.4inches (620mm)
 Depth: 25.6 inches (650mm)
 Height: 23.6inches (600mm)
 Weight: 150lb (68kg)
 PD1 Power Distribution Center:
 AC 100-240VAC 50/60HZ or DC 12V 300W 25 Amps

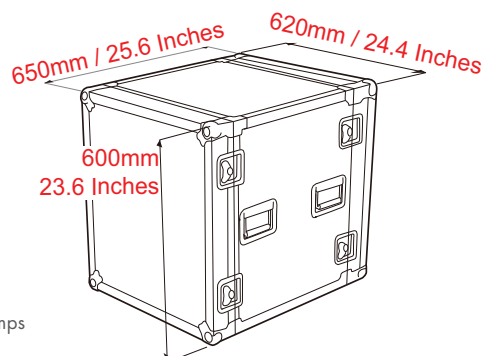

Example Setup Diagram

MS-900 MOBILE STUDIO SETUP

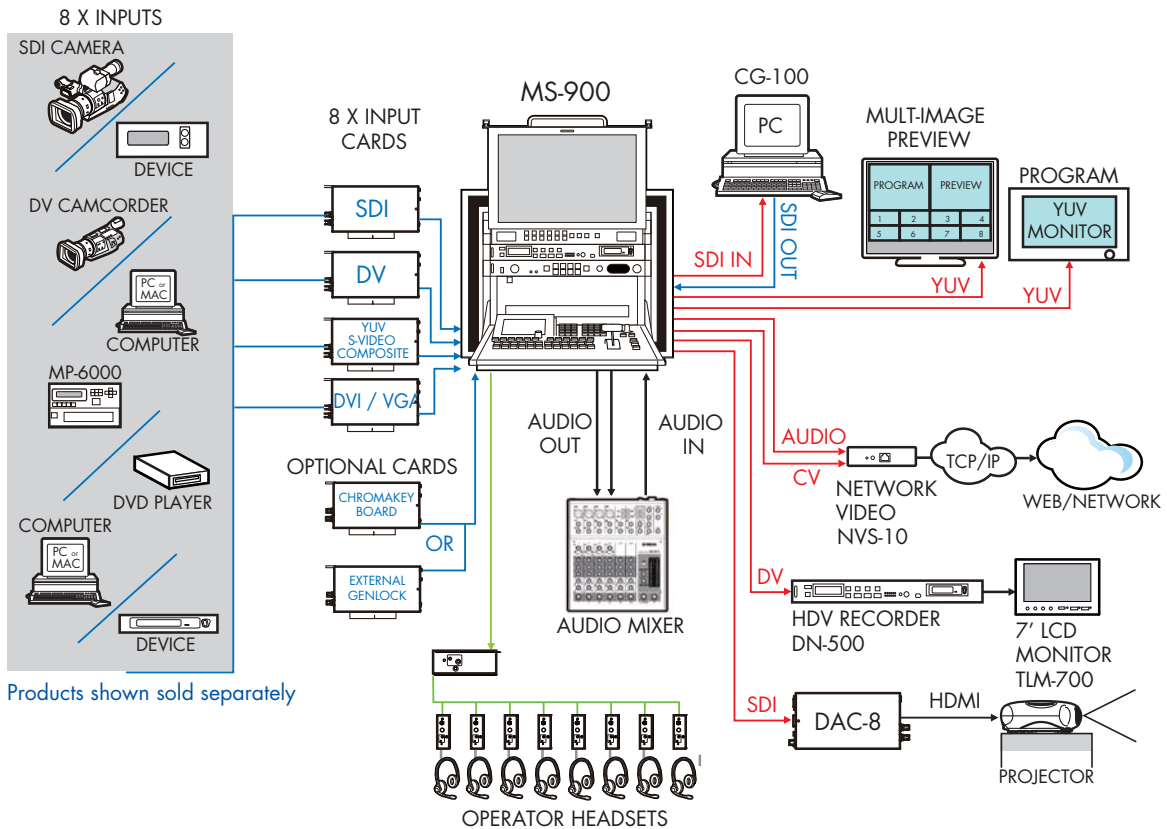

Products shown sold separately

What to Order

MS-900 MOBILE STUDIO - NTSC / PAL

MS-900 includes Datavideo's SE-900 switcher with a pull-out, flip-up monitor that displays all incoming sources, preview and program outputs using the SE-900's multi-image output.

MS-900 DV KIT

Includes 6x DV input cards, 2x YUV, CV, S, input cards, and 8 input SD switcher with RS-232/422 interface; and analog audio inputs on motherboard. In addition, keyboard, multi image preview card, SDI CG overlay card; and CV, YUV, S, DV video output cards, and 1 Chromakey card.

MS-900 STD KIT

Includes 4x DV input cards, 4x YUV, CV, S, input cards, and 8 input SD switcher with RS-232/422 interface; and analog audio inputs on motherboard. In addition, keyboard, multi image preview card, SDI CG overlay card; and CV, YUV, S, DV video output cards, and 1 Chromakey card.

MS-900 SDI KIT

Includes 6x SDI input cards, 8 input SD switcher, RS-232/422 interface; and analog audio inputs on motherboard. In addition, keyboard, multi image preview card, SDI CG overlay card; CV, YUV, S, DV video output cards, and 1 Chromakey card

MS-900 YUV KIT

Includes 8x YUV, CV, S, input cards, 8 input SD switcher with RS-232/422 interface; analog audio inputs on motherboard. Keyboard, multi image preview card, SDI CG overlay card; and CV, YUV, S, DV video output cards, and 1 Chromakey card are also included.

MS-900 BROADCASTER

TLM-170M, 2x TB-5, NVS-10, DN-400 or DN-500, 1x Chromakey Card. Pick from 6x YUV, CV, S Input Card and 6x DV Input Cards, assembled in a 8U aluminum case.

CB-3 / CB-4 / CB-76

These are 5 pin intercom and tally cables that comes in the following length: CB-3 is a 20M (65ft), CB-4 is a 50M (164ft), CB-76 is a 76M(250ft).

MP-6000

A DVD+R/RW recorder with DV input; allows recordings from most A/V sources including: cameras and analog VCRs.

HD-40 / 50

A SD/HDI-SDI recorder with 250 GB removable HDD and two hard drive enclosures included.

TB-5

A tally box that comes with 4 indicators compatible with both the Datavideo SE-500 and SE-900.

PCR-100SDI Workstation with Software / Decklink SDI

Workstation with software for CG-100SDI installed in a HP Compaq 6000 Pro Micro tower PC ; includes a HP Compaq 19" widescreen LCD monitor and Decklink SDI card.

CA-SDI 50 / 100 / 150

A male to male BNC cable for 50 foot, 100 foot or 150 foot correspondingly to the model number.

NVS-10 (Optional)

A network video server that converts composite video with into MPEG-4 video streaming format.

CKL-200

Includes one Datavideo LD-1 blue/green LED ring, 1 brightness control power supply, 3 camera adaptor rings in 82mm, 72mm, and 58mm; and 2 Datavideo RF-1225FP (Fire retardant Chromakey fabric).